

# RCB32-E15T

## Features

- > Type B for charging piles and compatible with A+6 type on-board residual current protection module
- > All-in-One highly integrated digital residual current action indicator

## Standard

- > Meets the requirements of GB/T 40820 (IEC 62955) for the residual current operation characteristics of the mode three charge RDC-PD
- > Meets the basic residual current operating characteristics requirements of GB/T 22794 (IEC 62423) and adapts to DC 6mA test requirements

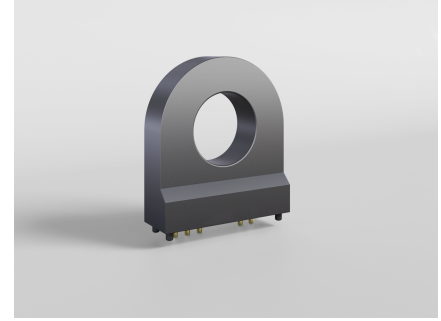

Product Appearance

### Trip-Current (residual current related characteristics)

Wav.	Freq.	Min.	Typ.	Max.	Unit
AC	50Hz	20.0	23.0	26.0	mA
A0	50Hz	11.0	20.0	30.0	mA
A90	50Hz	10.0	20.0	30.0	mA
A135	50Hz	10.0	28.0	35.0	mA
2PDC	50Hz	3.5	5.2	7.0	mA
3PDC	50Hz	3.1	4.6	6.2	mA
S-DC	-	3.0	4.6	6.0	mA
F	-	27.0	33.0	38.0	mA

### Trip-Time (residual current related characteristics)

Wav.	Freq.	Current	Typ.	Unit
AC	50Hz	30mA	110.0	ms
AC	50Hz	60mA	55.0	ms
AC	50Hz	150mA	15.0	ms
AC	50Hz	500mA	10.0	ms
AC	50Hz	420mA	40.0	ms
A0	50Hz	42mA	20.0	ms
A0	50Hz	84mA	15.0	ms
A0	50Hz	350mA	40.0	ms
A0	50Hz	42mA+6mADC	20.0	ms
A0	50Hz	84mA+6mADC	13.0	ms
A0	50Hz	350mA+6mADC	40.0	ms
2PDC/3PDC	50Hz	60mA	13.0	ms
2PDC/3PDC	50Hz	120mA	40.0	ms
2PDC/3PDC	50Hz	300mA	10.0	ms
S-DC	-	6mA	130.0	ms
S-DC	-	60mA	40.0	ms
S-DC	-	300mA	10.0	ms
F	-	210mA	13.0	ms

### Electrical & Reliability Characteristics

Char.	Value
Working Temperature	-40°C~105°C
Storage Temperature	-40°C~105°C
Working humidity	≤95%
Supply Voltage (VDD) <sup>(1)</sup>	4.85~5.15 VDC
Consumption	≤110 mW
Voltage Input, low level	0~0.6VDC
Voltage Input, high level	4.2~5VDC
FIT <sup>(2)</sup>	Contact us
Designed Life <sup>(3)</sup>	≥ 20 years
Working Altitude <sup>(4)</sup>	≤ 4000m

<sup>(1)</sup> It is suggested to control VDD within 4.9~5.1 VDC to get better performance

<sup>(2)</sup> The calculation of FIT according to IEC 61709, is based on the FIT values of different components in the BoM list. And the calculation principle: ground mobile, no dust or harmful substances

<sup>(3)</sup> The calculation and claim of product life is based on the MTBF value according to IEC 61709

<sup>(4)</sup> The calculation about altitude is based on the principles: reinforced insulation, insulation material group 3, pollution degree 2, overvoltage category 3

# RCB32-E15T

## Typical Application Schematic & Pin Definition

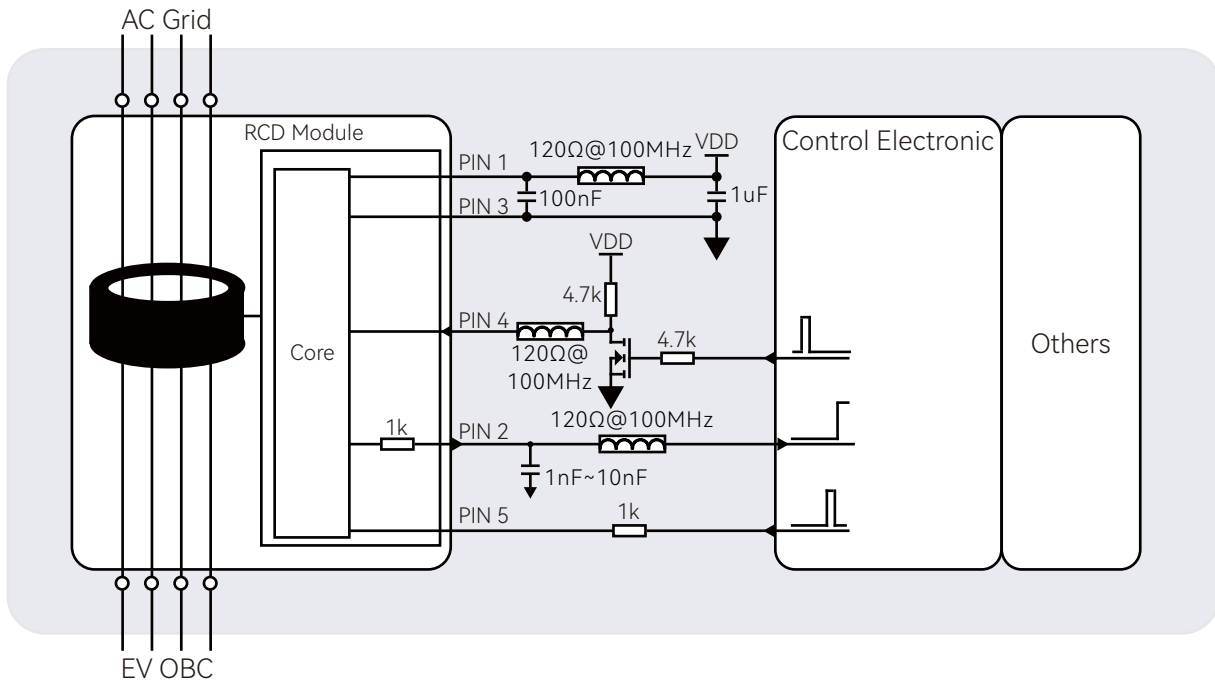

Pin-No.	Pin Name	Function
PIN-1	VDD	<ul style="list-style-type: none"> <li>&gt; Product power supply pin, standard power supply voltage 5 VDC</li> <li>&gt; The input voltage range is required to be 4.85-5.15 VDC, and the power output capacity should be &gt;100mA</li> <li>&gt; Power ripple <math>\leq</math> 150mV</li> <li>(It is recommended to use an LDO circuit, refer to the power chip LP2985A-50DB)</li> <li>&gt; Suggest adding magnetic beads and filtering capacitors on the power supply end, and placing them near the pins</li> </ul>
PIN-2	TRIP	<ul style="list-style-type: none"> <li>&gt; Product action signal output pin</li> <li>&gt; When residual current in the circuit is detected to exceed the threshold, the output level changes from low to high</li> <li>&gt; Suggest adding magnetic beads and filtering capacitors on the power supply end, and placing them near the pins</li> </ul>
PIN-3	GND	<ul style="list-style-type: none"> <li>&gt; Product power grounding pin</li> </ul>
PIN-4	CAL (Calibration)	<ul style="list-style-type: none"> <li>&gt; Product calibration command input pins</li> <li>&gt; When the pin is pulled down to a low level for 50-100ms and then restored to a high level, the product enters calibration mode</li> <li>&gt; When using this pin function, it is generally necessary to ensure that the charging circuit is disconnected during the self check process of the charging station to prevent residual current in the circuit from affecting the zero calibration effect during the zero calibration process</li> <li>&gt; When using this pin, be sure to design according to the recommended timing logic</li> <li>&gt; Suggest adding magnetic beads to the PIN pin and placing them close to the pin</li> </ul>
PIN-5	TEST (Self Test)	<ul style="list-style-type: none"> <li>&gt; Product self inspection input pins</li> <li>&gt; Before turning on charging, a simulation test is performed on the product by pulling the pin up to VDD to verify whether the product functions properly</li> </ul>

# RCB32-E15T

## Product Dimension

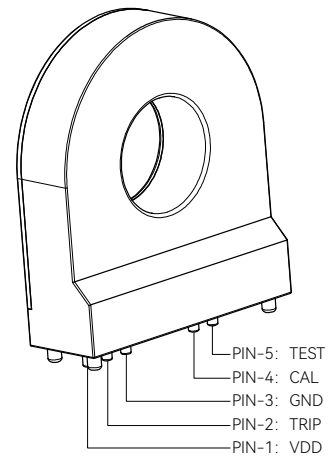
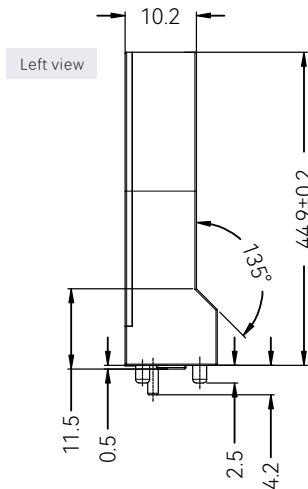
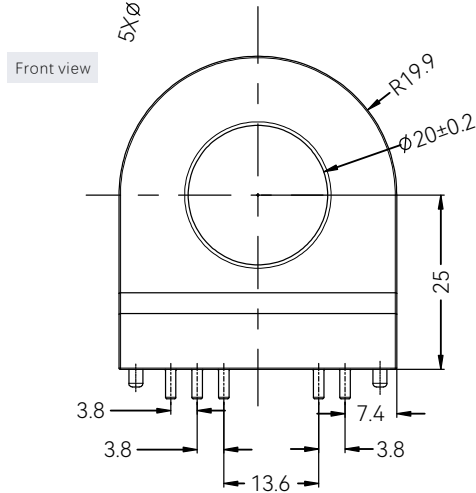
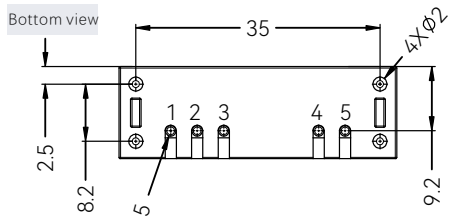

3D simulation

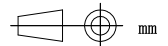
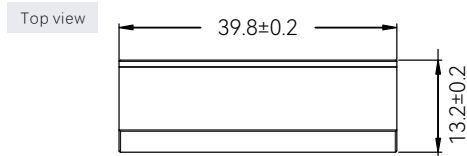

\* The limit deviation of unmarked dimensional tolerance shall be in accordance with GB/T 14486-MT5/B

Dimensions in mm

## Timing Diagram

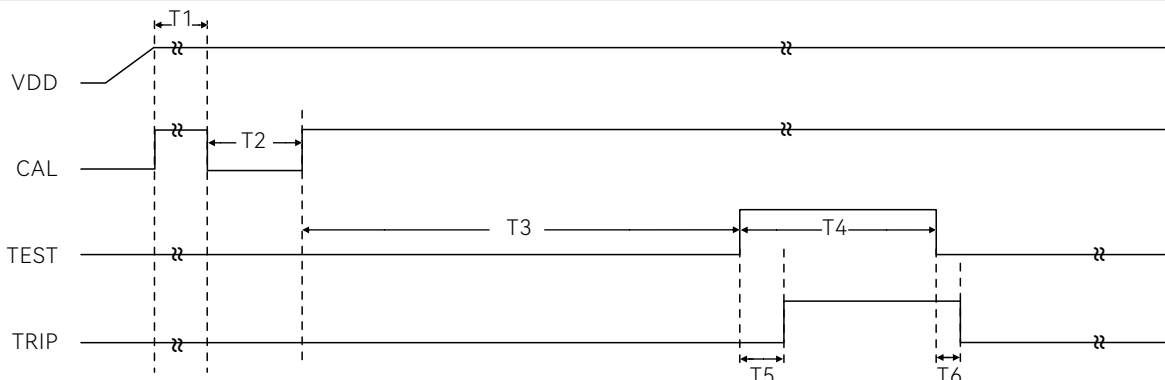

- > It is recommended to start VDD from 0V, and the power-on process is monotonous with a time of <math>< 15\text{ms}</math>
- > T1 is the waiting time after power on, and it is recommended that  $T1 \geq 100\text{ms}$
- > T2 is the internal calibration command of the system. It is recommended that  $50\text{ms} \leq T2 \leq 100\text{ms}$ . When the low level of the pin exceeds 50ms, the product begins to enter internal calibration
- > T3 is the waiting time for calibration completion, and it is recommended that  $T3 \geq 500\text{ms}$
- > T4 is the enabling time of the self check signal, and it is recommended that  $T4 \geq 400\text{ms}$
- > T5 is the delay time of the action signal, with  $T5 \approx 130\text{ms}$ . It is recommended to wait for 100ms after T5 ends to detect the action signal
- > T6 is the maintenance time of the action signal after the self check is completed, with  $T6 \approx 20\text{ms}$ . It is recommended to wait for 100ms after T6 to detect the action signal

Attention: During the self calibration process, i.e. (T1+T2+T3+T4), do not close the main circuit switch to prevent residual current in the circuit from affecting the self calibration process. After receiving the flip of the TRIP pin group, it can be determined whether the RCD module is working properly for subsequent operations

# RCB32-E15T

## Digital Signal Flip Threshold

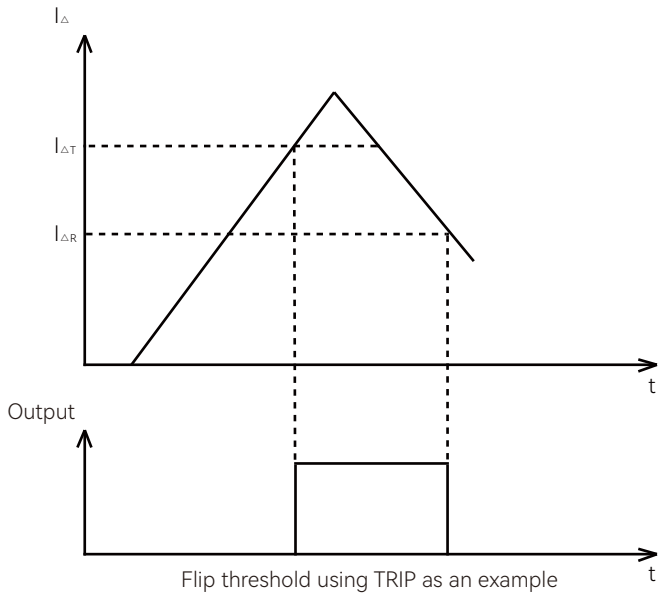

- > For avoiding the signal oscillation, tripping signal output flipping has been set with tripping threshold and recovery threshold
- > When tripping threshold  $I_{\Delta T}$  reached, the related X-OUT flip, and when the current decrease to the recovery threshold  $I_{\Delta R}$ , the related X-OUT flip again, back to low level state
- >  $I_{\Delta T}$  is set as 100% typical tripping value, and  $I_{\Delta R}$  is set as 55% typical tripping value

## Version history

Version number	Modifications	Reason for modification
V0.1.0	Create a new product specification	
V0.1.1	Update the product dimension drawing	Erratum
V0.1.2	Product specification review	Audit
V0.1.3	Update the product feature parameters	Update
V0.2.0	The UI of the product specification has been upgraded	

## Self-Test Circuit

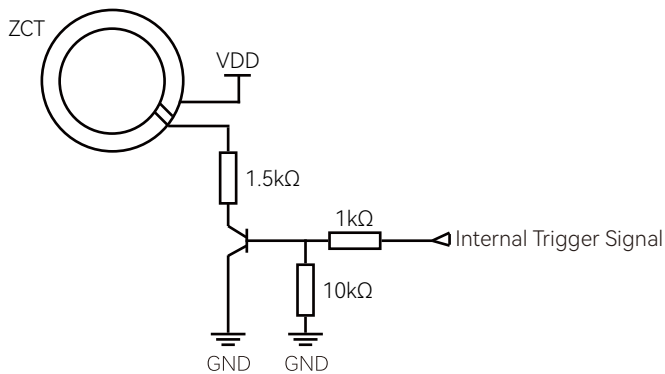

- > 2 winding on the ZCT to generate simulated DC residual current
- > By using VDD to generate typical value = 6.53 mADC simulated residual current
- > Use the most stringent 6mADC value to detect whether the module can work properly and identify residual current